

STEEL WASTE DISPOSAL TOP FOR DRUM - TRASH-TOP-ZGY

APPROX WEIGHT: 12.35 lbs.
 DOES NOT INCLUDE WEIGHT OF POWER OR PACKAGING!!!

ANY ADDITIONS, DELETIONS, OR OMISSIONS MUST BE CORRECTED ON THIS DRAWING AS THIS DRAWING WILL BE CONSIDERED ALL INCLUSIVE

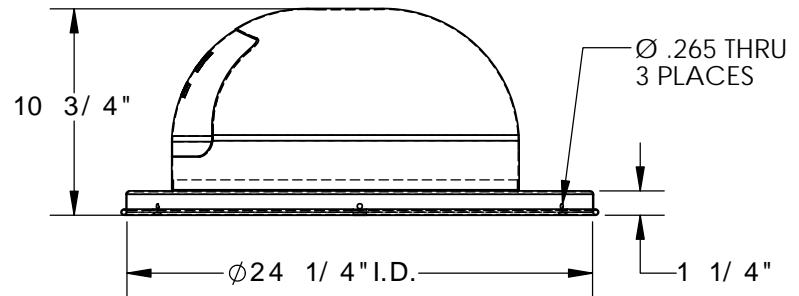
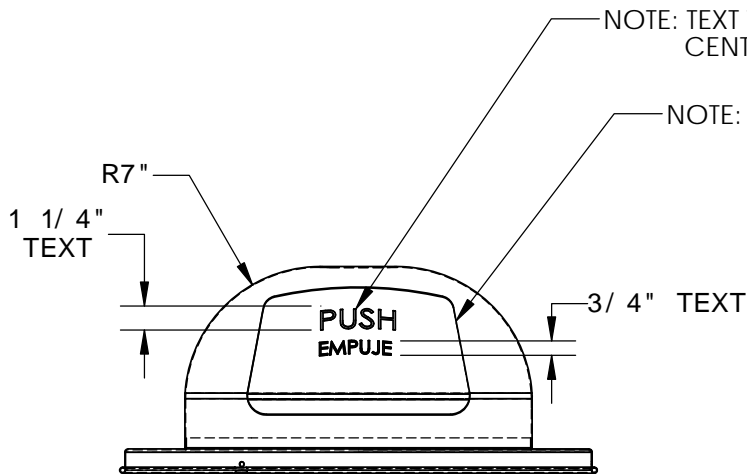
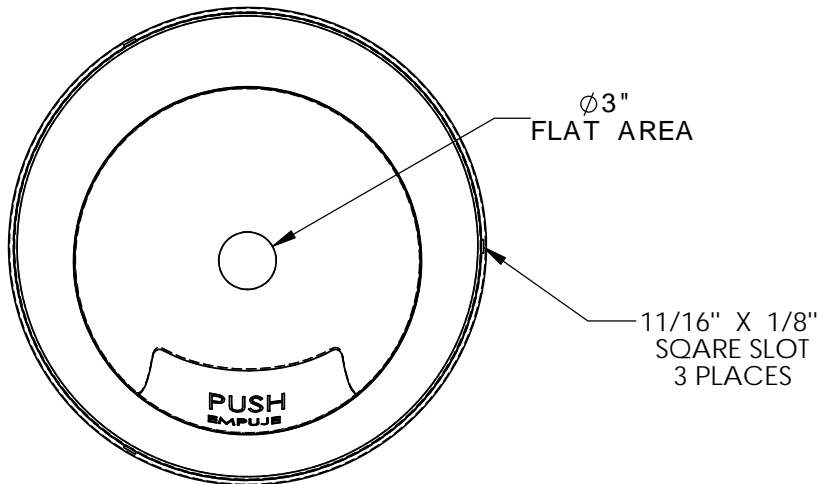

ALL GRAPHICS PROVIDED ARE FOR REFERENCE ONLY. IF CERTAIN DIMENSIONS ARE CRITICAL PLEASE VERIFY THOSE DIMENSIONS WITH YOUR SALESPERSON

NOTES:

COLOR / FINISH: TOUGH BAKED IN POWDER COATED GRAY FRINISH
 DRUM COVER MUST FIT A STANDARD U.S. 55 GALLON DRUM

A P P R O V A L	I, THE UNDERSIGNED, AGREE THAT THE PRODUCT AS REPRESENTED SATISFIES DESIGN AND DIMENSION REQUIREMENTS. I ALSO ACKNOWLEDGE MY DUTY TO CONFIRM PRODUCT AND INSTALLATION COMPLIANCE WITH ALL APPLICABLE FEDERAL, STATE AND LOCAL REGULATIONS AND STANDARDS.	
	ANY MODIFIED UNITS ARE NON-RETURNABLE	
	[] As drawn [] As marked	
	Signed: _____	Date: _____
Printed Name: _____		
<i>LEAD TIME WILL START UPON RECEIPT OF SIGNED APPROVAL DRAWING</i>		

FOR INTERNAL USE ONLY PROJECT SIGN OFF		DISTRIBUTOR'S NAME: VESTIL MANUFACTURING		P.O.# X
SALES		DRAWN BY: TAL		W.O.# X
ENG.		DATE: 8/15/2016	SALES: X	
FAB.		REFERENCE: X	SCALE: 1:10	FILE NAME:
POWER		QUOTED LEAD TIME: X	QUOTE # X	30-007-269